

HOT-END WORK

HEYE

full cycle
cooling for
high speed
production



Full cooling power is ensured during the entire process cycle

Conventional cooling of the blow mould unit operates only in certain mould positions. Consequently, consistent cooling of the mould cannot be ensured for the entire forming cycle at blow side, resulting in less container stability and less production speed.

NEW BLOW MOULD AXIAL COOLING

The latest Heye blow mould axial cooling is capable of permanently cooling the moulds during the entire process cycle. Thus, compared to other cooling systems, a much better cooling performance can be achieved. Regardless of mould open or closed position, full cooling power is ensured during the entire process cycle. Double tele-

scopic tubes with large cross-sections provide for maximum volume flow. Thanks to an improved cooling piece design, optimized flow paths are ensured. This provides increased stability, better quality and higher production speeds. The axial cooling can be refitted on existing IS-machines.

OPTIMIZED FLOW PATHS

Large tube cross-sections and

double telescopic tubes provide for maximum volume flow. In the area of the telescopic tubes, the flow path is nearly straight; in the area of the ball joints it is redirected very slightly. The cooling piece distributes the cooling air in fan-shaped pattern equally on the mould halves.

EASY JOB CHANGE

A specially developed cooling piece holder enables to perform

blow mould holder exchange quickly and easily. By loosening a few screws, the holder can be separated simply from the cooling piece.

FLEXIBILITY BY TELESCOPIC TUBES

Axial cooling can be applied for different glass container heights. The telescopic tubes flexibly adapt to the different distances between cooling foot and mould holder. For very short moulds, the distance can be compensated by an additional cooling piece adapter.

ADVANTAGES

- High cooling efficiency by double telescopic tubes
- Uniform cooling air distribution on the moulds
- Optimized flow design

- Compatibility for different holder applications
- Easy and quick job change

Carefully selected variables and spare parts guarantee high process quality.

Heye International stands for innovative design, combined with precise manufacturing and long lifetime. Lately, the new 360° blow mould axial cooling has impressively proven its benefits under glass in a Mexican container glass operation.

HEYE INTERNATIONAL

Based in Obernkirchen, Germany, Heye International

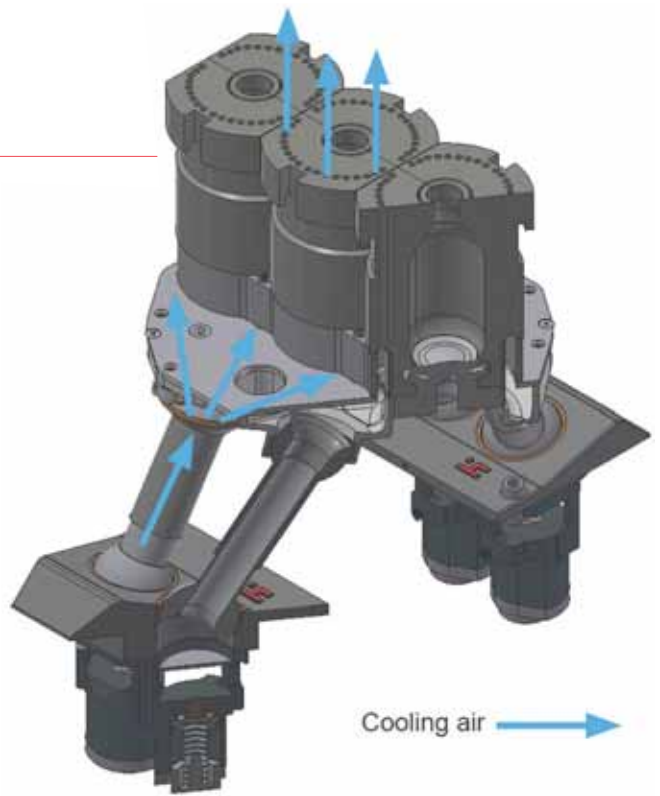

Optimized flow paths

More power by double telescopic tubes

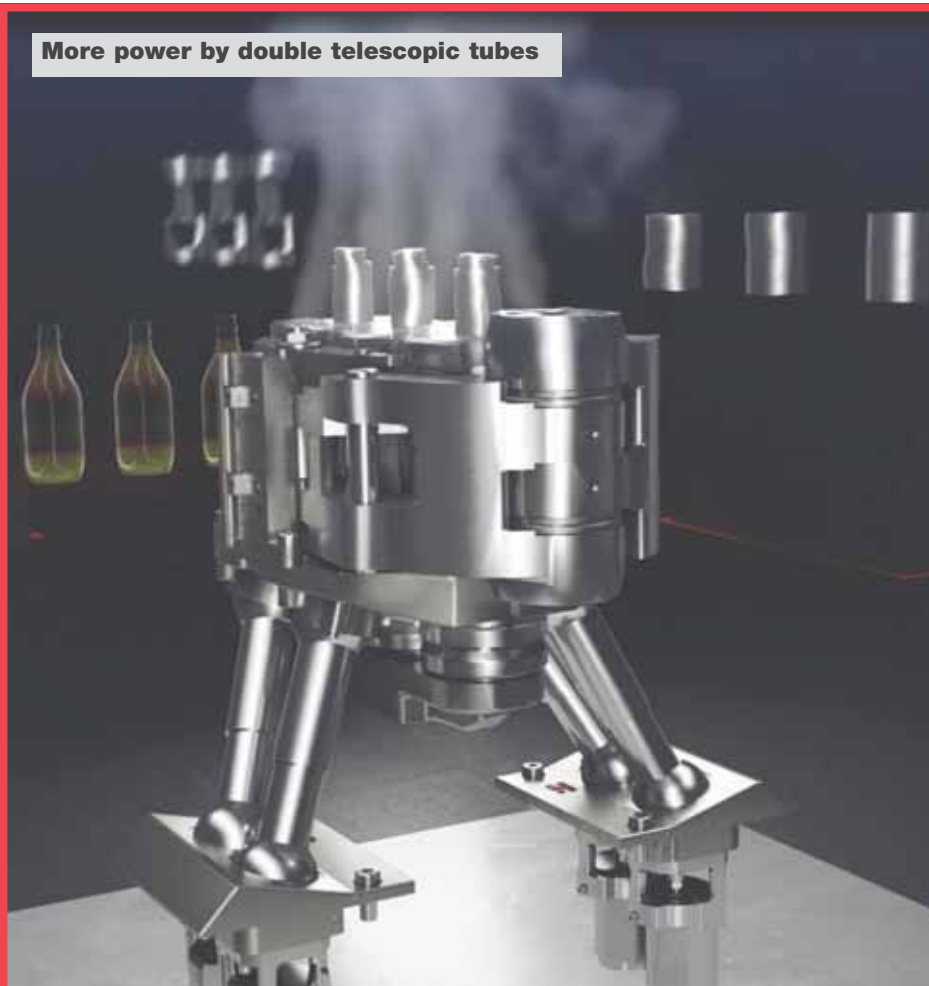

is one of the international glass container industry's foremost suppliers of production technology, high performance equipment and production knowhow. Its mechanical engineering has set industry standards for more than five decades. Extensive industry expertise, combined with the positive attitude and enthusiasm of Heye International employees is mirrored by the company motto 'We are Glass People'. Its three sub-brands HiPERFORM, HiSHIELD and HiTRUST form the Heye Smart Plant portfolio, addressing the glass industry's hot end, cold end and service requirements respectively. ■



HEYE INTERNATIONAL GMBH

Lohplatz 1
31683 Obernkirchen - Germany
Telephone: +49 (0)5724 26-0
Fax: +49 (0)5724 26-539.

www.hey-international.com